



Electrolux
PROFESSIONAL

**Modular Cooking Range Line
700XP Two Well Freestanding
Electric Fryer 2x14 liter (Marine)**

ITEM # _____

MODEL # _____

NAME # _____

SIS # _____

AIA # _____



371164 (E7FRMH2FF5)

14+14-lt electric Fryer free standing with 2 wells (internal heating elements), 2 baskets and lids included - Marine

Short Form Specification

Item No. _____

To be installed on height adjustable feet in stainless steel. High efficiency tilting incoloy armoured heating elements (17.4kW) placed inside the well. Deep drawn well. Oil drains through a tap into a container under the well. Exterior panels in stainless steel with Scotch Brite finish. One piece pressed work top in 1.5 mm thick stainless steel. Right-angled side edges to allow flush-fitting junction between units.

Main Features

- IPx4 water protection.
- Unit to be mounted on height adjustable feet in stainless steel.
- Optional portable oil quality monitoring tool (code 9B8081) for efficient oil management.
- Incoloy armoured heating elements located inside the well can be lifted up for easier cleaning.
- Oil drains through a tap into a drainage container positioned under the well.
- Thermostatic regulation of oil temperature up to a maximum of 185 °C.
- Overheat protection thermostat as standard on all units.
- All major compartments located in front of unit for ease of maintenance.

Construction

- Interior of well with rounded corners for ease of cleaning.
- Model has right-angled side edges to allow flush fitting joints between units, eliminating gaps and possible dirt traps.
- One piece pressed 1.5 mm work top in Stainless steel.
- All exterior panels in Stainless Steel with Scotch Brite finishing.

APPROVAL: _____



Experience the Excellence
www.electroluxprofessional.com

Included Accessories

- 1 of Flanged feet kit PNC 206136
- 2 of Door for open base cupboard PNC 206350
- 2 of 1 full size basket for 14/15lt fryers PNC 921691

Optional Accessories

- Junction sealing kit PNC 206086
- Kit 4 wheels - 2 swivelling with brake - it is mandatory to install Base support and wheels PNC 206135
- Flanged feet kit PNC 206136
- Support for bridge type installation, 1600mm PNC 206141
- Frontal kicking strip for concrete installation, 800mm PNC 206148
- Frontal kicking strip for concrete installation, 1200mm PNC 206151
- Frontal kicking strip for concrete installation, 1600mm PNC 206152
- Frontal kicking strip, 800mm (not for refr-freezer base) PNC 206176
- Frontal kicking strip, 1000mm (not for refr-freezer base) PNC 206177
- Frontal kicking strip, 1200mm (not for refr-freezer base) PNC 206178
- Kit 4 feet for concrete installation (not for 900 line free standing grill) PNC 206210
- Pair of side kicking strips PNC 206249
- Pair of side kicking strips for concrete installation PNC 206265
- Right and left side handrails PNC 206307
- Back handrail 800 mm PNC 206308
- Back handrail 1200 mm PNC 206309
- Door for open base cupboard PNC 206350
- Base support for feet or wheels - 800mm (700/900) PNC 206367
- Base support for feet or wheels - 1200mm (700/900) PNC 206368
- Base support for feet or wheels - 1600mm (700/900) PNC 206369
- Rear paneling - 600mm (700/900XP) PNC 206373
- Rear paneling - 800mm (700/900) PNC 206374
- Rear paneling - 1000mm (700/900) PNC 206375
- Rear paneling - 1200mm (700/900) PNC 206376
- Chimney grid net, 400mm (700XP/900) PNC 206400
- 2 side covering panels for free standing appliances PNC 216000
- 1 full size basket for 14/15lt fryers PNC 921691
- 2 half size baskets for 14/15lt fryers PNC 921692
- Filter for fryer oil collection basin for 7lt, 14lt, 15lt free standing fryers PNC 921693

Front

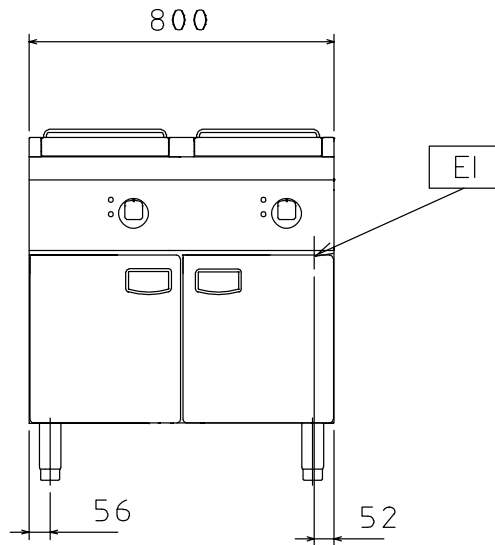

Side

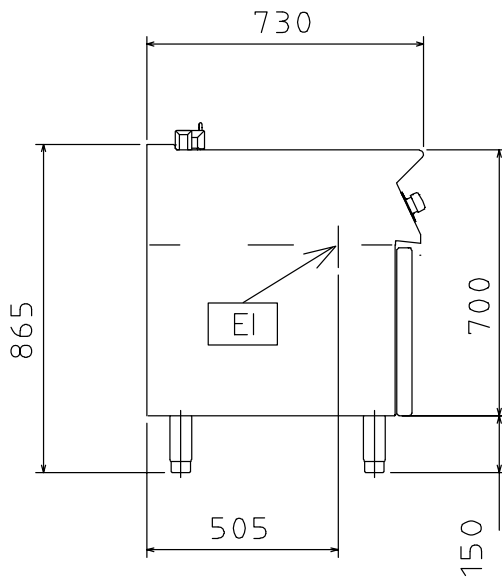

EI = Electrical inlet (power)
EQ = Equipotential screw

Top

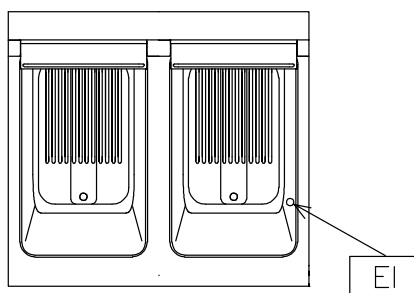

Electric

Supply voltage:	380-400 V/3 ph/50/60 Hz
Predisposed for:	
Total Watts:	17.4 kW

Key Information:

If appliance is set up or next to or against temperature sensitive furniture or similar, a safety gap of approximately 150 mm should be maintained or some form of heat insulation fitted.

Usable well dimensions (width):	240 mm
Usable well dimensions (height):	285 mm
Usable well dimensions (depth):	380 mm
Well capacity:	12 lt MIN; 14 lt MAX
Thermostat Range:	105 °C MIN; 185 °C MAX
Net weight:	81 kg
Shipping weight:	85 kg
Shipping height:	1140 mm
Shipping width:	820 mm
Shipping depth:	860 mm
Shipping volume:	0.8 m ³
Certification group:	EF17114